

Stainless steel

TECHNICAL DATA BALL VALVE:

Body material:	Stainless steel 1.4408
Flange material:	Stainless steel 1.4408
Screw ring	Stainless steel 1.4408
Ball material:	Stainless steel 1.4401
Ball seat:	R-PTFE (15%)
Stem material:	Stainless steel 1.4401
Stem packing:	PTFE FKM O-Ring
Body wall thickness:	Acc.to EN 12516-1
Flange connection:	Acc.to DIN 2501/1 - EN 1092-1
Face to face dimension:	Acc.to EN558-1 Row 27
ISO Flange:	Acc.to DIN EN ISO 5211
Safety:	Blow-out proofed, antistatic
Medium temperature:	-25°C up to max. +180°C, pressure dependent
Pressure rating:	Max. PN 40 bar, temperature dependent
Approval:	ATEX II 2G Ex h IIB T2 Gb ATEX II 2D Ex h IIIB T280° Db

TECHNICAL DATA ACTUATOR

Functionality :	*OPEN* * CLOSE
Control voltage :	AE01: 230V AC 50/60 Hz. AE02: 24V DC
Power consumption :	AE01: 6 W AE02: 8 W
Operating temperature :	- 25°C up to max. + 55°C
Operating time :	approx. 15 sec. for 90° at 18 Nm
Angle of rotation :	set 90 ° for ball valves max. 360 °
Torque max :	18 Nm
Protection class :	IP 64
Electrical connection :	1 external plug for voltage 1 external plug for signal
Limit switch :	2 pieces for 90° rotation 2 pieces for feedback *Open* *Close*
Position indicator:	optical
Actuator connection:	Acc.to DIN EN ISO 5211 [direct assembly]
Star:	F03 F04 F05 square 9x9 11x11
Housing cover:	Aluminium alloy coated
Manual override:	Allen key

Flange connection

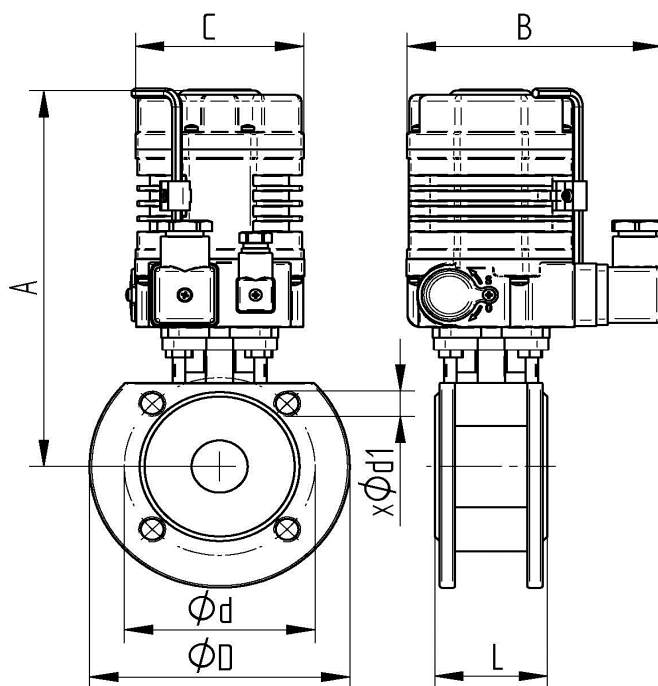

Item Nr. 230V 50 Hz.	Item Nr. 24V DC	DN	A mm	B mm	C mm	L mm	øD mm	ød mm	ød1 mm
AE01 0939-04	AE02 0939-04	15	174	116	75	36	95	65	4xM12
AE01 0939-05	AE02 0939-05	20	179	116	75	38	105	75	4xM12
AE01 0939-06	AE02 0939-06	25	178	116	75	50	115	85	4xM12