

TECHNISCHE DATEN

Gehäuse:	Edelstahl 1.4301
Spindel:	Edelstahl 1.4301
Spindeldichtung:	PTFE
Mutter, Scheiben, Verdrehsicherung:	Edelstahl 1.4301

Verwendbar für folgende Kugelhähne:

920; 930; 931; 939;
9651; 9652
9336; 9337; 9338; 9339; 9342; 9343;

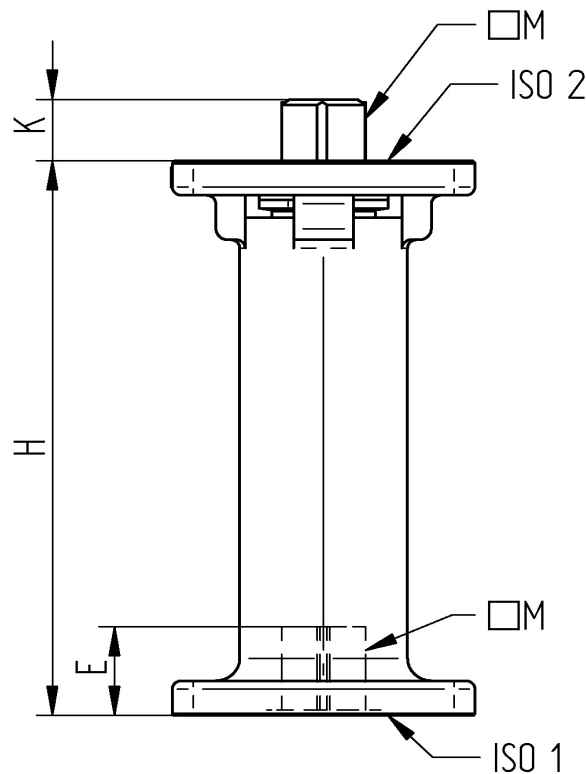

Art.Nr.	DN	H	M	E	K	ISO1	ISO2
98000920-1520	15 20	100	9	12	9	F04	F03 F04
98000920-2532	25 32	100	11	16	11	F05	F04 F05
98000920-4050	40 50	100	14	17	14	F07	F05 F07
98000920-6580100	65 80 100	100	17	21	17	F10	F07 F10
980009221-100	100	100	22	25	22	F12	F10 F12
98000920-125150200	125 150 200	100	22	25	22	F13	F10 F13