

### TECHNISCHE DATEN

Gehäuse:	Edelstahl 1.4301
Spindel:	Edelstahl 1.4301
Spindeldichtung:	PTFE
Mutter, Scheiben:	Edelstahl 1.4301
Verdrehsicherung:	Edelstahl 1.4301

### Verwendbar für folgende Kugelhähne:

920; 921; 930; 931; 932; 939  
 9650; 9651; 9652  
 9323; 9325; 9334; 9335; 9336; 9337; 9338; 9339; 9342; 9343

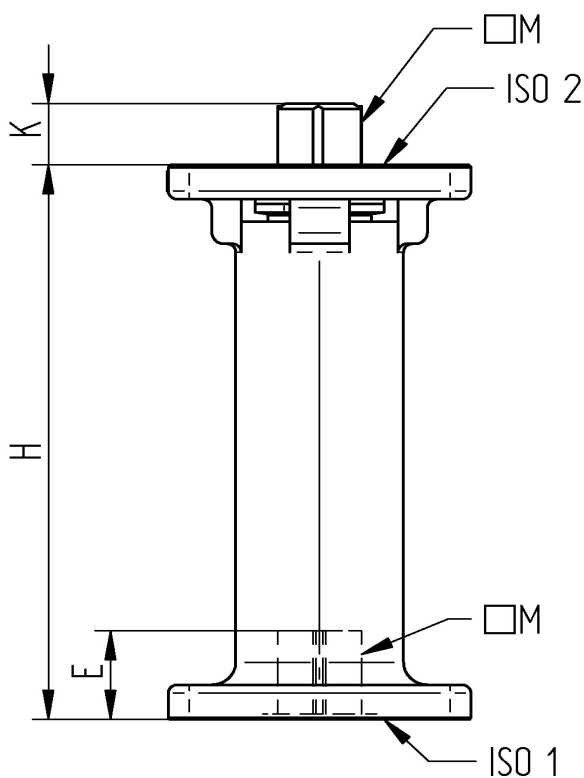

Art.Nr.	DN	H	M	E	K	ISO1	ISO2
98000920-1520	15   20	100	9	12	9	F04	F03   F04
98000920-2532	25   32	100	11	16	11	F05	F04   F05
98000920-4050	40   50	100	14	17	14	F07	F05   F07
98000920-6580100	65   80   100	100	17	21	17	F10	F07   F10
98000920-125150	125   150	100	22	25	22	F10   F12	F10   F12
98000920-200	200	100	27	30	27	F12   F14	F12   F14