

Stainless steel

TECHNICAL DATA

Construction: 1-way angle seat valve, pneumatically controlled
 Control function: Normally closed against flow direction
 Spring-return closing - Pneumatic opening
 Connection thread: According to DIN EN ISO 228-1
 Operating temperature: -10°C to +180°C, pressure-dependent
 Ambient temperature: -10°C to max. +60°C
 Operating pressure: max. 16 bar
 Control pressure: 3 bar–10 bar
 Control air connection: G 1/8" / G 1/4"

Valve body: Edelstahl 1.4408
 Piston housing: Edelstahl 1.4308
 Stem: Edelstahl 1.4408
 Seal material: PTFE / RTFE
 Stem seal: PTFE / FKM
 Piston seal: FKM / NBR



CLOSED

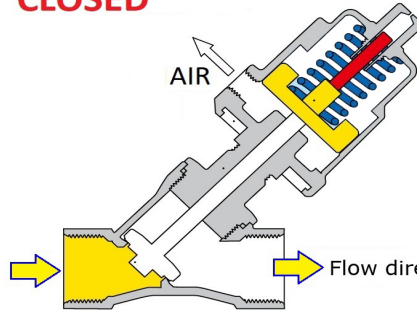

OPEN

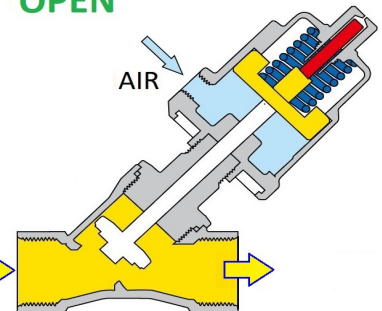

Connecting thread female/female

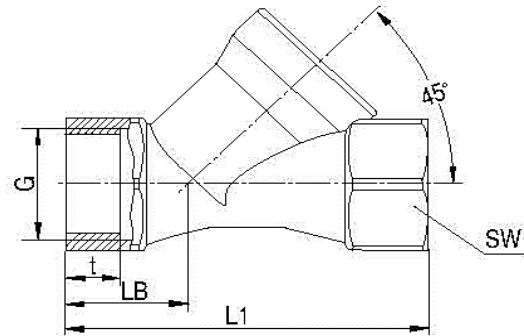
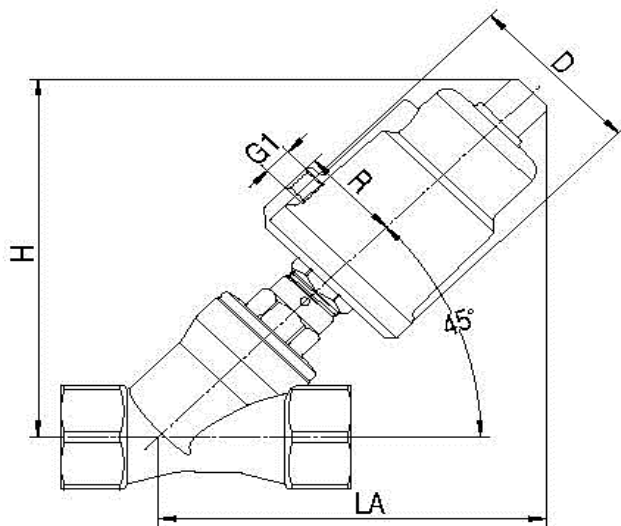

Item No.	G	DN	Actuator	H mm	LA mm	D mm	R mm	G1	L1 mm	LB mm	SW mm	t mm	PN	Weight	Kv-Wert(m3/h)	
9696	-04	1/2"	15	50	121	121	62	34	1/8"	74	25,5	25	11,5	16	1,12 kg	4,7
9696	-05	3/4"	20	50	125	125	62	34	1/8"	84	29	31	14	16	1,23 kg	9,5
9696	-06	1"	25	50	131	131	62	34	1/8"	100	33,5	39	15	16	1,46 kg	18,1
9696	-07	1 1/4"	32	63	161	161	77	42	1/8"	112	36	50	18	16	2,75 kg	23,1
9696	-08	1 1/2"	40	63	169	169	77	42	1/8"	126	41	56	18	16	3,00 kg	32,9
9696	-09	2"	50	63	180	180	77	42	1/8"	146	46	68	22	16	3,80 kg	52,8