

Stainless steel

TECHNICAL DATA BALL VALVE:

Construction:	2-way full bore ball valve
Design:	2-part design
Connection end:	Flange according to DIN 2501/1-EN 1092-1
Body:	Stainless steel 1.4408
Ball:	Stainless steel 1.4401
Stem:	Stainless steel 1.4401 Blow-out proof
Ball seal:	PTFE TFM1600
Stem seal:	PTFE FKM O-ring
Body wall thickness:	According to EN 12516-1
Face to face dimension:	According to EN 558-1 series 27
Flange PN40	DN15-DN50
Flange PN16	DN65-DN200
Actuator connection:	Acc.to DIN EN ISO 5211 [direct assembly]
Medium temperature:	-20°C to +180°C pressure dependent
Medium nominal pressure:	Max. 40 bar temperature-dependent
Inspection&Test :	DIN 3230/3 - EN 12266

TECHNICAL DATA ACTUATOR

Functionality :	*OPEN* * CLOSE
Control voltage :	AE01: 230V AC 50/60 Hz. AE02: 24V DC
Power consumption :	AE01: 6 W AE02: 8 W
Operating temperature :	- 25°C up to max. + 55°C
Operating time :	approx. 15 sec. for 90° at 18 Nm
Angle of rotation :	set 90 ° for ball valves max. 360 °
Torque max :	18 Nm
Protection class :	IP 64
Electrical connection :	1 external plug for voltage 1 external plug for signal
Limit switch :	2 pieces for 90° rotation 2 pieces for feedback *Open* *Close*
Position indicator:	optical
Actuator connection:	Acc.to DIN EN ISO 5211 [direct assembly]
Star:	F03 F04 F05 square 9x9 11x11
Housing cover:	Aluminium alloy coated
Manual override:	Allen key

Flange connection

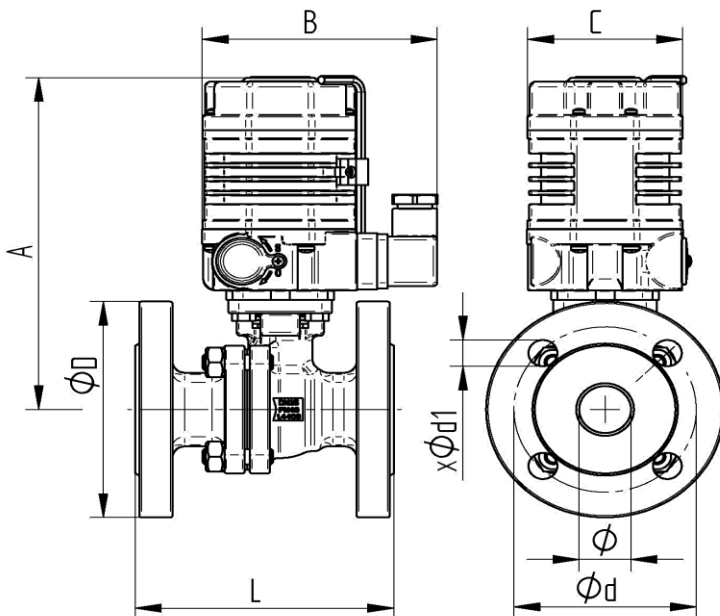

Item Nr. 230V 50 Hz.	Item Nr. 24V DC	DN	øR mm	A mm	B mm	C mm	L mm	øD mm	ød mm	xød1 mm
AE010921-04	AE020921-04	15	15	169	116	75	115	95	65	4xø14
AE010921-05	AE020921-05	20	20	174	116	75	120	105	75	4xø14
AE010921-06	AE020921-06	25	25	180	116	75	125	115	85	4xø14