

Hot pressed brass

TECHNICAL DATA

| | |
|---------------------|------------------------------------|
| Construction: | 1-way check vane |
| Design: | horizontal vertical |
| Connection end: | Thread acc. to DIN EN ISO 228-1 |
| Cap: | Brass CW617N |
| Swift disc: | Brass CW617N |
| Cap sealing: | Fiber |
| Disc sealing: | Metallic |
| Medium temperature: | 0°C up to +90°C pressure-dependent |
| Nominal pressure: | Max. 16 bar temperature-dependent |



Connecting thread female/female

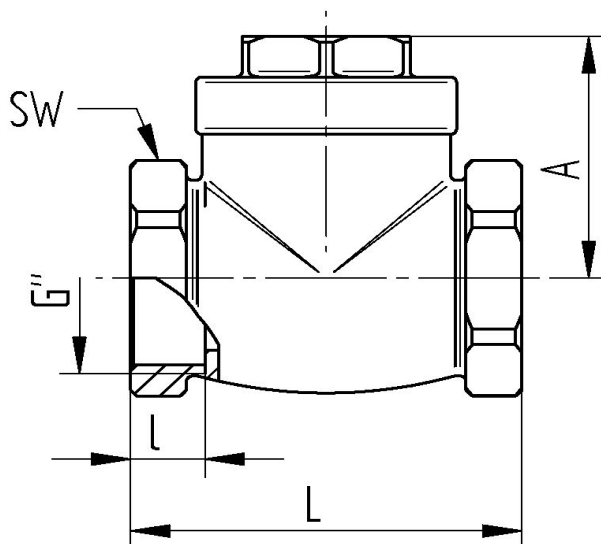

| Art. Nr. | G" | øDN | A mm | I mm | L mm | SW mm | weight (g) |
|----------|--------|-----|------|------|------|-------|------------|
| 1052-03 | 3/8" | 12 | 32 | 12 | 43 | 25 | --- |
| 1052-04 | 1/2" | 14 | 32 | 12 | 47 | 25 | 175 |
| 1052-05 | 3/4" | 20 | 36 | 12 | 53 | 31 | 224 |
| 1052-06 | 1" | 25 | 42 | 12 | 63 | 37 | 335 |
| 1052-07 | 1 1/4" | 30 | 51 | 14 | 70 | 46 | 509 |
| 1052-08 | 1 1/2" | 35 | 62 | 14 | 88 | 55 | 827 |
| 1052-09 | 2" | 47 | 64 | 17 | 97 | 67 | 1145 |
| 1052-10 | 2 1/2" | 60 | 75 | 21 | 120 | 81 | 1788 |
| 1052-11 | 3" | 74 | 77 | 21 | 135 | 96 | 2770 |
| 1052-12 | 4" | 95 | 90 | 21 | 162 | 124 | 4640 |