

Gray cast iron GG25

TECHNICAL DATA

Working temperature :	-10°C up to max. +150°C, pressure dependent
Working pressure:	max. PN 16 bar
Flange connection:	according to UNI EN 1092-1 with trough hole, except DN125-DN150
Actuator connection:	according to DIN EN ISO 5211
Body material :	gray cast iron GG25, coated
Case material:	gray cast iron GG25, coated
Ball:	brass MS 58, hard chrome-plated
Ball seals:	PTFE
Stem :	steel-9 SMnPb 36
Stem seals :	PTFE HNBR O-Ring
handle:	steel, black plastic coated
Overall length :	according to EN 558-1 F4



Flangeconnection

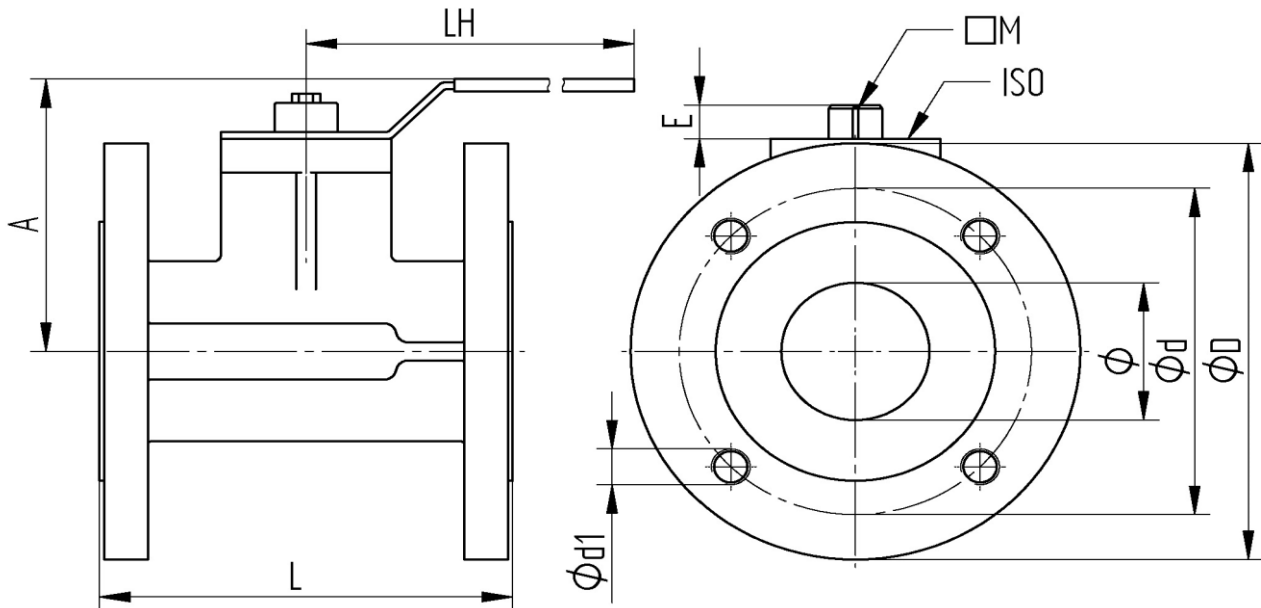

Art.Nr.	DN	ø	L mm	A mm	LH mm	øD mm	ød mm	ød1 mm	M mm	E mm	øISO	PN bar	weight (Kg)
909-06	25	25	125	77	200	115	85	4xø14	9	10	F 04	16	3,6
909-07	32	32	130	82	200	140	100	4xø18	9	10	F 04	16	4,8
909-08	40	40	140	92	240	150	110	4xø18	14	13	F 05	16	6,2
909-09	50	50	150	99	240	165	125	4xø18	14	13	F 05	16	9,0
909-10	R65	61	170	121	260	185	145	4xø18	17	15	F 07	16	12,2
909-11	R80	74	180	130	260	200	160	8xø18	17	15	F 07	16	15,0
909-12	R100	95	190	144	260	220	180	8xø18	17	15	F 07	16	20,0
909-13GW	R125	120	200	185	450	250	210	8xM16	22	20	F 10	16	28,0
909-14GW	R150	145	210	204	450	285	240	8xM20	22	20	F 10	16	38,5