

Manually operated

Technical data

Body:	Spheroid ductile iron GGG40 blue RAL5002 coated
Design:	Split body
Disc:	Stainless steel 1.4408
Seat:	PTFE+FKM
Shaft:	Stainless steel 1.4034
Shaft sealing:	PTFE+FKM O-Ring
Overall length:	Acc.to DIN EN 558-1
Actuator connection:	Acc.to DIN ISO 5211
Flange connection:	Acc.to UNI EN 1092, PN06 - PN10 - PN16
Medium temperature:	-10°C up to +150°C pressure dependent
Pressure rating:	Max. 16 bar temperature dependent
Ratchet handle lever:	≤DN125 Aluminum black coated
Worm gear box:	≤DN125 on Request ≥DN150 Aluminum black coated

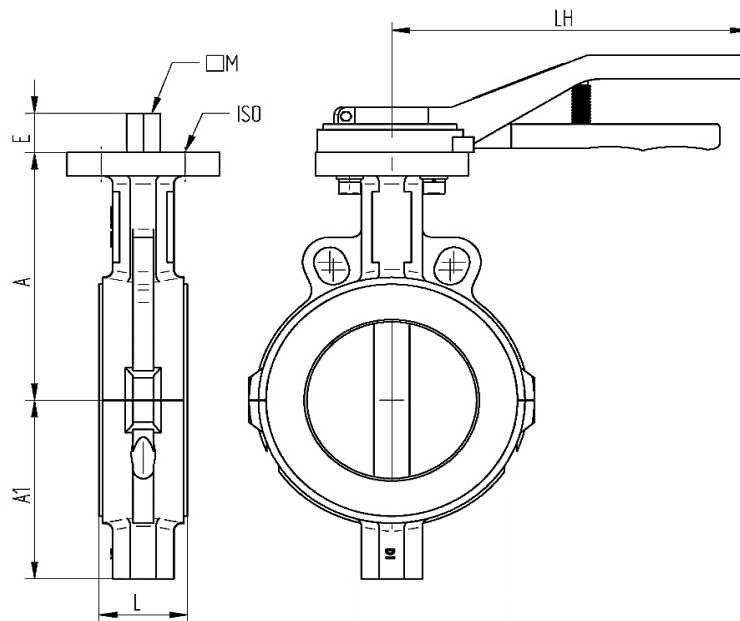

Item No. Size	DN	L mm	A mm	A1 mm	LH mm	E mm	M mm	øISO	PN	Nm	Kg
5400-08	40	43	136	65	210	25	11	F05 F07	16	40	3,70
5400-09	50	43	136	65	210	25	11	F05 F07	16	40	3,70
5400-10	65	46	140	72	210	25	11	F07	16	48	4,10
5400-11	80	46	140	80	210	25	11	F07	16	56	4,70
5400-12	100	52	158	114	210	25	14	F07	16	82	7,50
5400-13	125	56	170	125	210	25	14	F07	16	112	8,60

Worm gear box with handwheel

5400-14	150	56	190	138	-	25	17	F07	16	150	11,00
5400-15	200	60	232	171	-	35	17	F07	10	270	20,05
5400-16	250	68	270	209	-	25	22	F10	10	375	25,55
5400-17	300	78	300	230	-	30	22	F10	10	500	43,55

08/2024