

Carbon Steel

Technical data

Body:	Carbon Steel 1.0737 galvanized
Body caps:	Carbon Steel 1.0737 galvanized
Connection:	Threaded ends acc. to DIN EN ISO 228-1
Ball:	Carbon Steel 1.0737 chromated
Ball seat:	POM
Stem:	Carbon Steel 1.0737 galvanized
Stem packing:	NBR POM
Medium temperature:	≤DN25: -20°C up to +100°C pressure dependent ≥DN32: -30°C up to +100°C pressure dependent
Pressure rating:	Max. 500 bar temperature dependent
On request	High temperature gasket options

Application

Particularly suitable for oil-hydraulic, industrial plants in generally suitable, which have high pressure exhibit aufweisen.

Approval

- ATEX nach 2014/34/EU
- EAC nach TR CU 010/2011



FE/FE acc.to DIN EN ISO 228-1

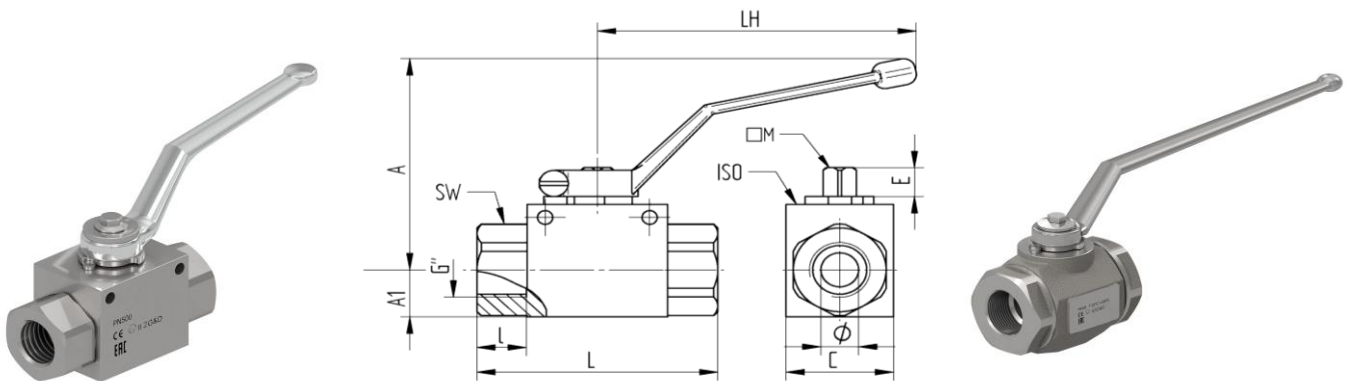

Item Size 02-06 [without ISO BORE]
Die-cast zinc handle

Item Gr. 02-06 [without ISO BORE]

Item Size 07-09 [without ISO BORE]
Die-cast zinc handle

Item No.	G"	DN	L mm	A mm	B mm	I mm	LH mm	G mm	F mm	E mm	M mm	PN bar	Weight (Kg)
4500-02	1/4"	6	71	35	14,5	87	110	30	49	11	9	500	0,49
4500-03	3/8"	10	73	40	17,4	93	110	35	54	11	9	500	0,64
4500-04	1/2"	13	83	43	19,7	97	110	37	57	11	9	500	0,76
4500-05	3/4"	20	95	57	25,4	105	180	49	75,5	14	14	420	1,44
4500-06	1"	25	112	65	29,5	113	180	55	83,5	14	14	420	2,22
4500-07	1 1/4"	32	115	89	42,5	162,5	310	85	107,5	14	17	420	4,49
4500-08	1 1/2"	40	131	106	52,5	179,5	310	105	124,5	14	17	420	6,75
4500-09	2"	50	140	115,5	58,5	189	310	117	134	14	17	420	8,71

10/2023